



PROFESSIONAL AUDIO SYSTEM

# SP320



OPERATING MANUAL

Ver. SP320-EN-1.0

**LSS Advanced Speaker Systems**

Via On. Longo 53-89024 Polistena (RC) ITALY Tel (39) 966 9321299 – Fax (39) 966 933007 Email: info@lss.it - Internet: www.lss.it

## **NOTICE:**

LSS products are manufactured for use according to proper procedures by a qualified operator and only for the purposes described in this manual. The following conventions are used to indicate and classify precautions in this manual. Always heed the information provided with them. Failure to heed precautions can result in injury to people or damage to property.

## **© LSS, 2014**

All rights reserved. No part of this publication may be reproduced, stored in a retrieval system, or transmitted, in any form, or by any means, mechanical, electronic, photocopying, recording, or otherwise, without the prior written permission of LSS.

No patent liability is assumed with respect to the use of the information contained herein. Moreover, because LSS is constantly striving to improve its high-quality products, the information contained in this manual is subject to change without notice. Every precaution has been taken in the preparation of this manual. Nevertheless, LSS assumes no responsibility for errors or omissions. Neither is any liability assumed for damages resulting from the use of the information contained in this publication.

---

## SUMMARY

INTRODUCTION .....	4
SAFETY AND WARNING.....	5
APPLICATION.....	6
PHYSICAL DESCRIPTION.....	6
TECHNICAL SPECIFICATIONS .....	7
INSTALLATION AND WIRING .....	8
WEEE DIRECTIVE .....	12
TROUBLESHOOTING .....	13
DIMENSIONS.....	14
NOTES .....	15

## INTRODUCTION

Congratulation on the purchase of your new LSS loudspeaker. Quality innovation and versatility, this is a summary of the new system developed by LSS for professional sound users. LSS produces professional audio products – the result of exceptional engineering and meticulous craftsmanship. This manual is intended for use with LSS loudspeaker. This includes: safety precautions; installation, set-up and operating instruction. Please read this manual plus any accompanying manual and follow all relevant precautions and instructions. This should allow you to obtain the maximum performance from your new loudspeaker. Where there are conflicts or overlaps, the information in any accompanying manual supersedes the information in this manual.

## SAFETY AND WARNING

### IMPORTANT! SAFETY WARNING!

In the interest of their own and others' safety and to prevent voiding the warranty, we recommend a careful reading of this section before using the product.

- This product was designed and manufactured to be used as a speaker system in the context of a typical sound reinforcement system.

The use for any purpose other than these is not provided by the manufacturer and is therefore under the direct responsibility of the user / installer.

- This device complies with class I (must be connected to the outlet with a protective earthing connection).



#### WARNING

RISK OF ELECTRIC SHOCK  
DO NOT OPEN

TO REDUCE THE RISK OF ELECTRIC SHOCK  
DO NOT REMOVE COVER (OR BACK)  
NO USER SERVICEABLE PARTS INSIDE  
REFER SERVICING TO QUALIFIED SERVICE PERSONNEL  
TO REDUCE THE RISK OF FIRE OR ELECTRIC SHOCK  
DO NOT EXPOSE THIS EQUIPMENT TO RAIN OR MOISTURE

### TO AVOID THE RISK OF FIRE AND / OR ELECTRIC SHOCK\*:

- Do not expose this system to rain or moisture. Do not expose the apparatus to dripping or splashing water. Do not place objects filled with liquids, such as drinks, on the apparatus.

- Before connecting the system, be sure the mains voltage corresponds to that stated on the product.

- Connect this appliance to a power outlet with earth contact, according to national security force, via a power cable of adequate section ends with a plug or connector that meets the applicable safety regulations.

- The unit is connected to the network even when the power switch is in position '0' (OFF). Before any maintenance, disconnect the power cable from the outlet.

\*Risk of electric shock only for self-powered system.

### IMPORTANT! SAFETY PRECAUTIONS!

Read This First.

Read and heed all warnings and safety instructions in this Manual before using the product.

Failure to follow all precautions can result in equipment damage and / or personal injury.

1. Read these instructions.
2. Keep these instructions
3. Heed all warnings and follow all instructions.
4. Use only attachments/accessories specified by the manufacturer.
5. Use only with the cart, stand, tripod, bracket, or table specified by the manufacturer, or sold with the apparatus. When a cart is used, use caution when moving the cart/apparatus combination to avoid injury from tip-over.
6. Refer all servicing to qualified service personnel. Servicing is required when the apparatus has been damaged in any way, such as power-supply cord or plug is damaged, liquid has been spilled or objects have fallen into the apparatus, the apparatus has been exposed to rain or moisture, does not operate normally, or has been dropped.
7. LSS loudspeakers can produce sound levels capable of causing permanent hearing damage from prolonged exposure. The higher the sound level, the less exposure needed to cause such damage

CAUTION: This product is energized as long as it is connected to the AC.

CAUTION: Allow at least six inches of free space all around the amplifier for sufficient ventilation.

## APPLICATION

LSS's SP320 is a compact 2-WAY loudspeaker system designed as a dedicated top-box and should be supported by the PSUB1 or DG118 subwoofer below 100 Hz. SP320 houses a 200 mm (8") Ferrite mid-woofer and 26 mm (1") Mylar driver on Conical horn. The SP320 is ideal for medium and smaller clubs, dancefloors. The cabinet, offers built-in flying points for both horizontal and vertical mounting. The trapezoidal cabinet allows flexible fixing and easy construction of clusters and arrays. LSS's advanced crossover includes professional protection of POLISWITCH. The SP320 has a full range passive powering mode

The SP320 was designed for distributed systems. The pole mount cup and balance-optimized handles allow for quick and easy load-in for portable use. Its high output capabilities let it act as a main system for smaller or portable A/V events. The comprehensive system mounting points allow safe suspension in permanent installations.

## PHYSICAL DESCRIPTION

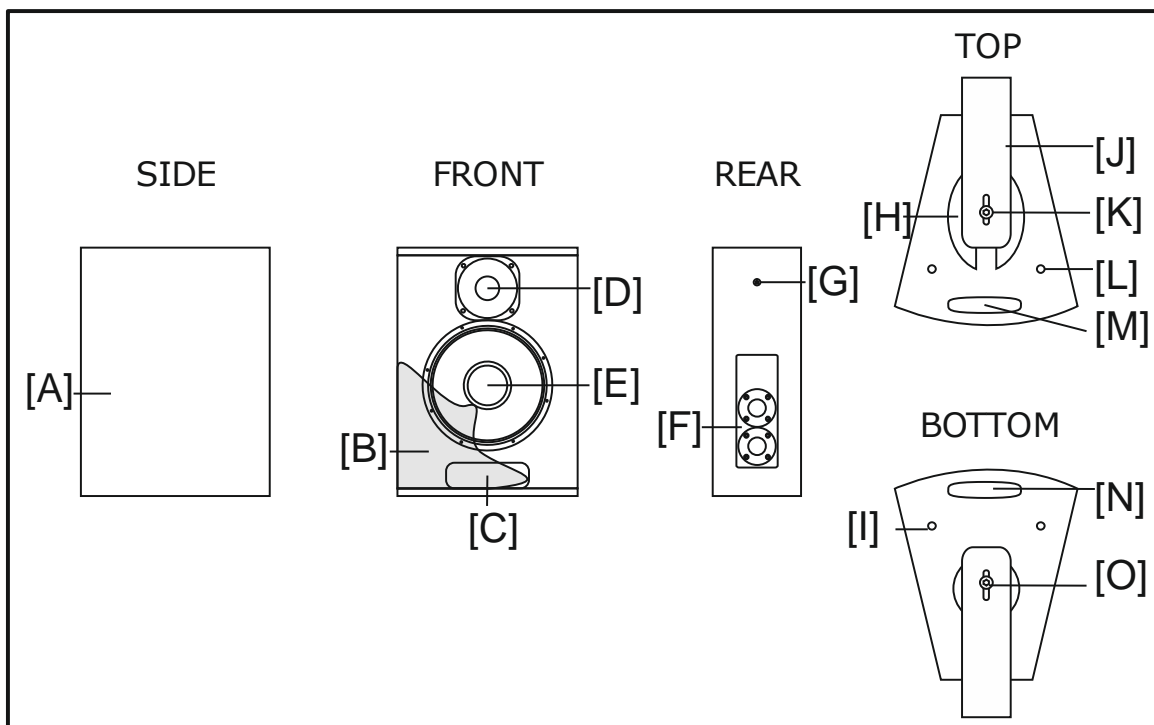

- [A] Enclosure Cabinet
- [B] Steel Protection Grid r
- [C] Reflex
- [D] HF Driver
- [E] Woofer
- [F] Connection Panel
- [G] Safety Fixing Point
- [H] Handle

- [I] Bottom Fixing Point
- [J] Mounting Bracket
- [K] Mounting Nut
- [L] Top Fixing Point
- [M] Handle
- [N] Handle
- [O] Mounting Nut

Materials and construction meet the highest professional standards to ensure maximum reliability

## TECHNICAL SPECIFICATIONS

<b>PHYSICAL</b>	<b>Dimensions mm (<math>\pm 1</math> mm) [Inches]</b>	Height 420 [16.53"]
		Front Width 306 [12.04"]
		Rear Width 150 [5.90"]
		Depth 345 [13.58"]
		Trapezoidal Angles 13°
	<b>Weight Kilograms</b>	Net Weight 11
		Shipping Weight 13
<b>SYSTEM PERFORMANCE</b>	<b>Frequency Response</b>	$\pm 5$ dB 60 Hz ~ 20 KHz
		-10 dB 50Hz
	<b>Sensitivity (1 Watt @ 1 m)</b>	Full Range Passive 94 dB
	<b>Max SPL Calculated</b>	118 dB
	<b>Nominal Input Impedance (<math>\Omega</math>)</b>	Full Range Passive 8 $\Omega$
		LF 8 $\Omega$
		HF 8 $\Omega$
	<b>Power Handling (Watt cont. AES)</b>	Full Range Passive 300
		LF 280
		HF 20
<b>Peak Power (W)</b>	1200	
<b>Nominal Dispersion (@ -6 dB)</b>	Horizontal 80°	
	Vertical 80 °	
<b>MECHANICAL</b>	<b>Enclosure material</b>	Birch Plywood of 15 mm [0.59"], MDF of 14 mm [0.55"]
	<b>Finish</b>	Texture poliuretanic black paint
	<b>Suspension</b>	7 point mounting suspension
	<b>Grille</b>	Powder coated perforated steel with anti-dust foam
	<b>Connectors</b>	2 Neutrik Speakon NL4
	<b>Accessories</b>	Mounting Bracket (Included) Fly clip with ring (Optional)

## INSTALLATION AND WIRING

SP320 speaker can be mounted to the wall or roof using its own bracket.

There are two plates provided with the speaker: one of them must be installed when using a mount pole, the other one must be used when using the mounting bracket to fix it.

When the Pole mount cup is used, speaker can be mounted on a tripod or on another speaker as a sub.

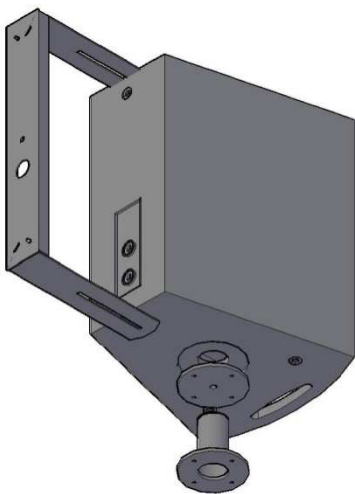
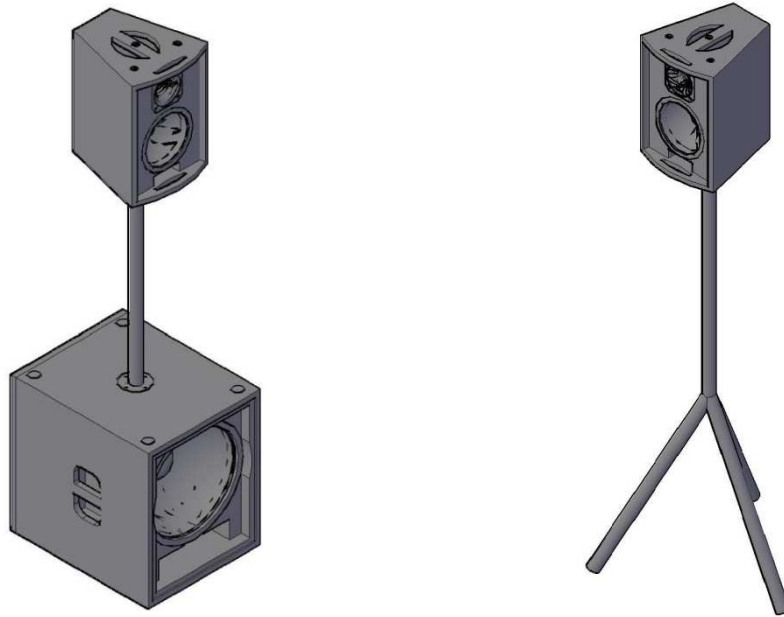

The bracket must be fixed to the wall through the fixing holes using plugs suitable to support the weight of the entire apparatus.

Bracket must be secured to the speaker with the screws on the top and bottom of the case.

Once the bracket is fixed to the support, you can rotate the case respect to the bracket.

Installation can be done either in vertical or horizontal position.

Choose a safe mounting location, so as to prevent the cables can be stepped on or create tripping hazards.

Make sure that the shape and extent of the supporting surfaces are such as to ensure a safe support.



In the back of speaker there are one other mounting hole, it can be used as safety fixing point if required.

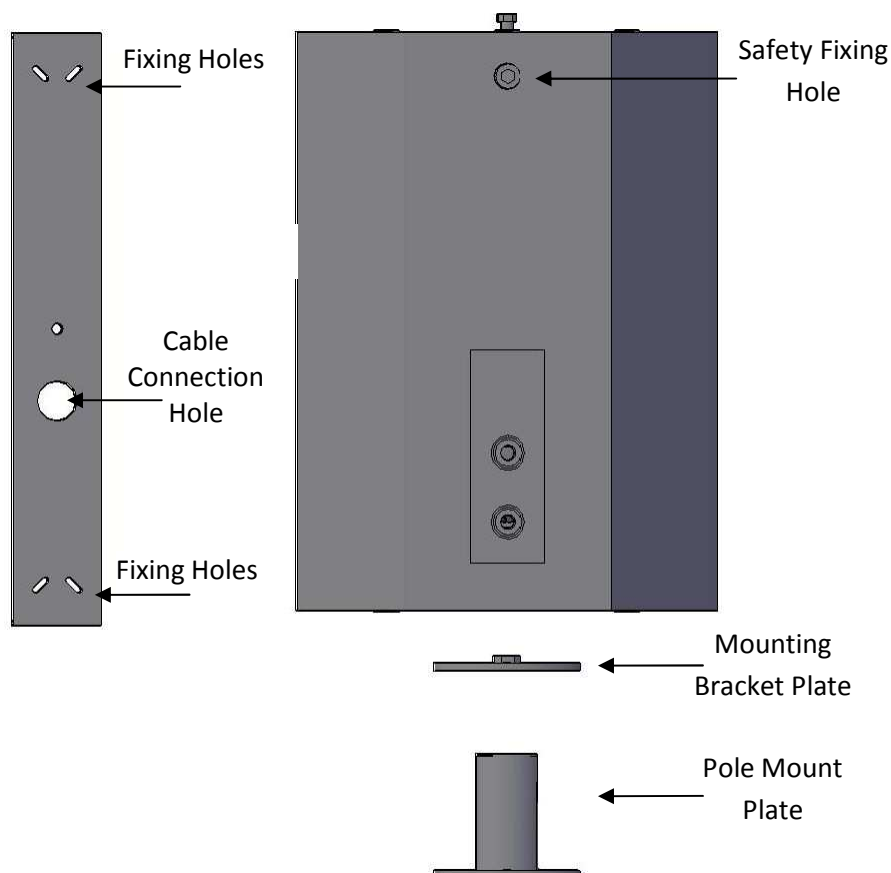

Before making connections between mixer and speakers, make sure the mixer volume is turned down.

In the connection panel there are two Speakon NL4 connectors referred as 'IN' and 'OUT'.

IN is the input connector and must be connected to the amplifier, 'OUT' is a LINK OUT and can be connected to other systems.

Recommended configuration in basic stereo system is represented below:

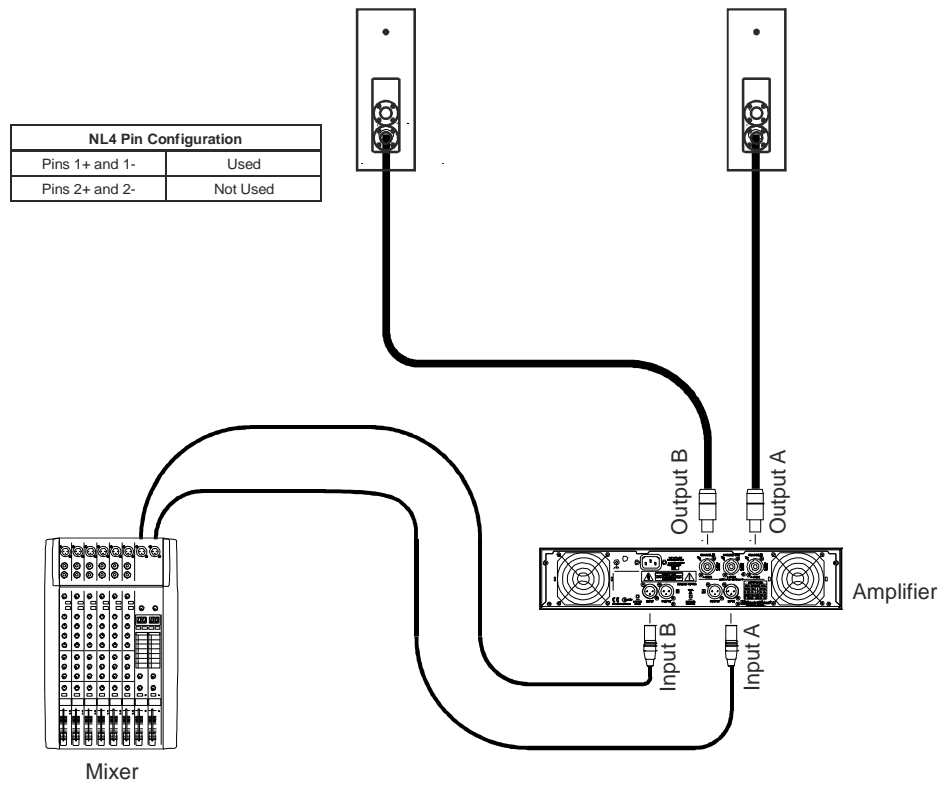

Recommended configuration using multiple speakers is represented below:

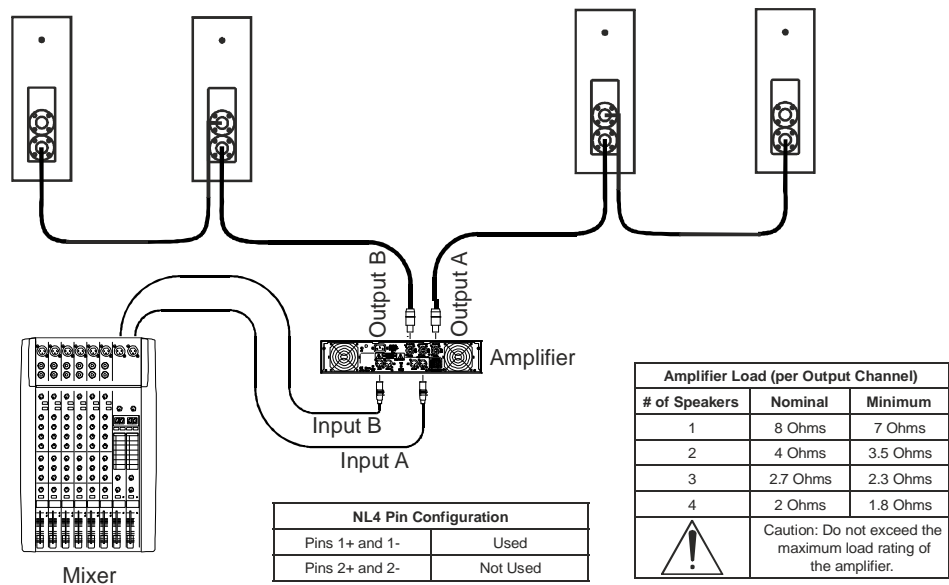

You can now use the system

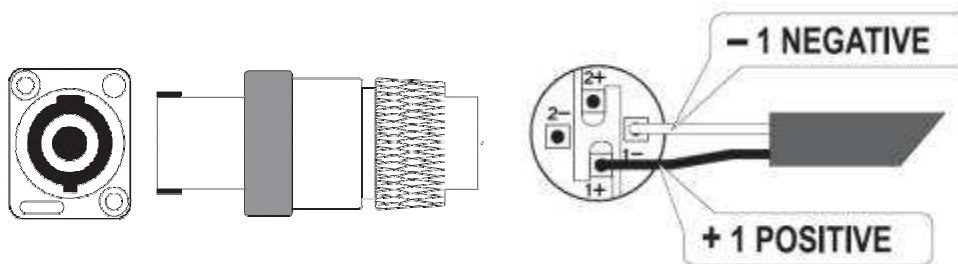
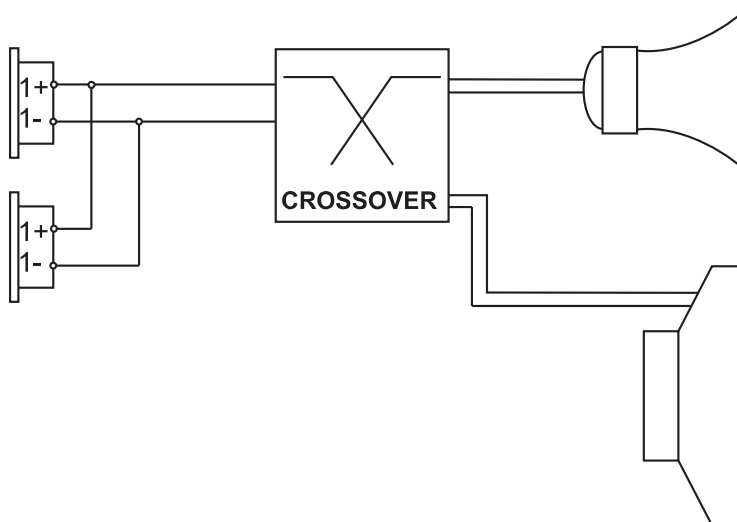

## WEEE DIRECTIVE

### WEEE Directive

#### Warning!

The product is marked with this symbol which indicates not to discard electrical and electronic equipment via the normal procedure for disposal of household waste. For these products there is a diverse collection system in accordance with legislation that requires proper treatment, recovery and recycling of used products. For more information please contact the appropriate local authority.

The black bar underneath indicates that the product was placed on the market after 13 August 2005.

### INFORMATION FOR PROPER DISPOSAL

#### For home users

##### In the European Union

Warning: To dispose of this equipment, do not use the ordinary dust bin!

The electrical and electronic equipment must be treated separately and in accordance with legislation that requires proper treatment, recovery and recycling of used products. Following the implementation by member states, private households within the EU can give free electrical and electronic equipment to designated collection facilities\*.

In some countries (\*), your local retailer may withdraw the old product for free if you purchase a new one of similar type.

\* For more information please contact the appropriate local authority.

**In countries outside the EU:** please contact your local authorities and ask for the correct method of disposal.

**In Switzerland:** Used electrical or electronic equipment can be returned free of charge to the dealer, even if you do not purchase a new product.

Further collection facilities are listed on the homepage or [www.swico.ch](http://www.swico.ch).  
[www.sens.ch](http://www.sens.ch).

#### For professional users

##### In the European Union

Warning: If the product is used for business purposes, the following steps to delete it:

contact your LSS dealer for information about the product recall.

Might be charged for the costs of collection and recycling. Small products (and amounts) might be taken back by your local collection facilities.

**In Spain:** contact the established collection system or the local authority for collection of used products.

**In countries outside the EU:** please contact your local authorities and ask for the correct method of disposal.



## TROUBLESHOOTING

Problem	Possible cause (s)	Action
1. No Sound	Amplifier	Connect a known working test speaker to the amplifier outputs. If there is no sound, check that all the electronics are on, the signal routing is correct, the source is active, the volume is turned up, and so on. Correct/repair/replace as necessary. If there is sound, the problem is in the wiring.
	Wiring	Verify that you have connected the correct wire pairs to the amplifier. Play something at low level through the amplifier (for example, from a CD player or tuner). Connect the test speaker in parallel with the malfunctioning line. If the sound level has gone or is very weak, the line has a short in it (possibly a severe scrape, pinch, or staple puncture). If the sound level is normal, the wire is open (possibly a cut wire or a missed connection). Using the test speaker, move down the line and test each connection/junction until you find the problem and correct it. Observe proper polarity.
2. Poor Low Frequency Response	Speakers wired out-of-polarity	When two speakers are connected out of polarity, the low frequencies will cancel each other acoustically. Carefully observe the wire markings or tracers on your speaker wires. Verify that the amplifier (+) terminal is connected to pin 1+ of the NL4 connector and the amplifier (-) terminal is connected to pin 1- of the NL4 connector.
3. Intermittent output such as crackling or distortion	Faulty Connection	Check all connections at amplifier and speakers to ensure they are all clean and tight. If the problem persists, it may be in the amplifier or wiring. See Problem 1 above.
4. Constant noise such as buzzing, hissing, humming	Defective amplifier or other electronic Devices	If the noise is present but no program material is playing, the likely cause is the signal chain in the electronics. Evaluate each component as necessary to isolate the problem.
	Poor system grounding or ground loop	Check and correct the system grounding, as required.
If these suggestions do not solve your problem, contact your nearest LSS dealer or LSS distributor.		

## DIMENSIONS

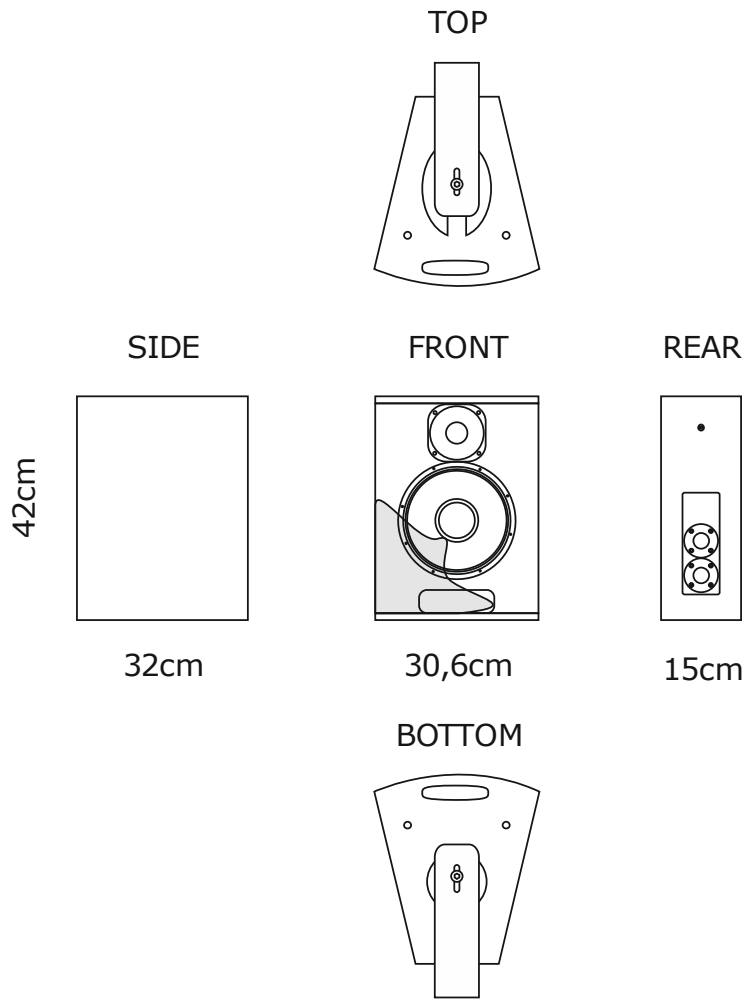

---

## NOTES



**CONTACT INFORMATION:**

**LSS Advanced Speaker Systems**

Via On. Longo 53  
89024 Polistena (RC) ITALY  
Tel (39) 966 9321299 – Fax (39) 966 933007  
Email: [info@lss.it](mailto:info@lss.it) - Internet: [www.lss.it](http://www.lss.it)